

DRG. NO. SHEET 1 OF 2  
**AO 289-10898**

CONFORMS TO BS 8888 THIRD ANGLE PROJECTION

REF	DRG No.	DESCRIPTION	QTY	REMARKS
1	289-10307	ADJUSTING PLATE	4	
2	289-10346	M6 SLOT SCREW ADAPTOR	4	
3	289-10894	VACUUM VESSEL TOP ASSEMBLY	1	
4	289-11672	O8 MAGNET ASSEMBLY	2	
5	289-11777	O8 MAGNET SUPPORT ASSEMBLY	2	
6	289-11862	VESSEL SUPPORT BEAM - LONG	2	
7	HHS-080-060	M8 x 60 LG HEX HD SCREW	12	
8	NUT-080	M8 HEX NUT	12	
9	SHS-060-020	M6 x 20 LG HEX SKT HD CAP SCREW	8	
10	SHS-060-040	M6 x 40 LG HEX SKT HD CAP SCREW	4	
11	WAS-080	M8 PLAIN WASHER	12	

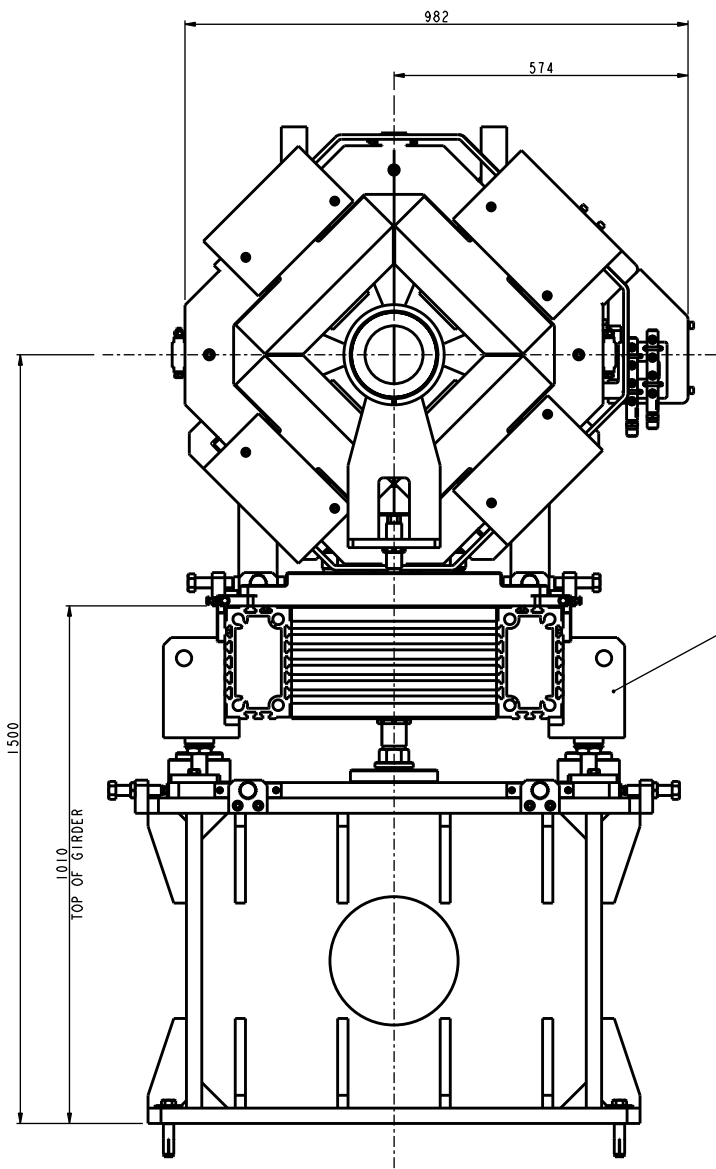
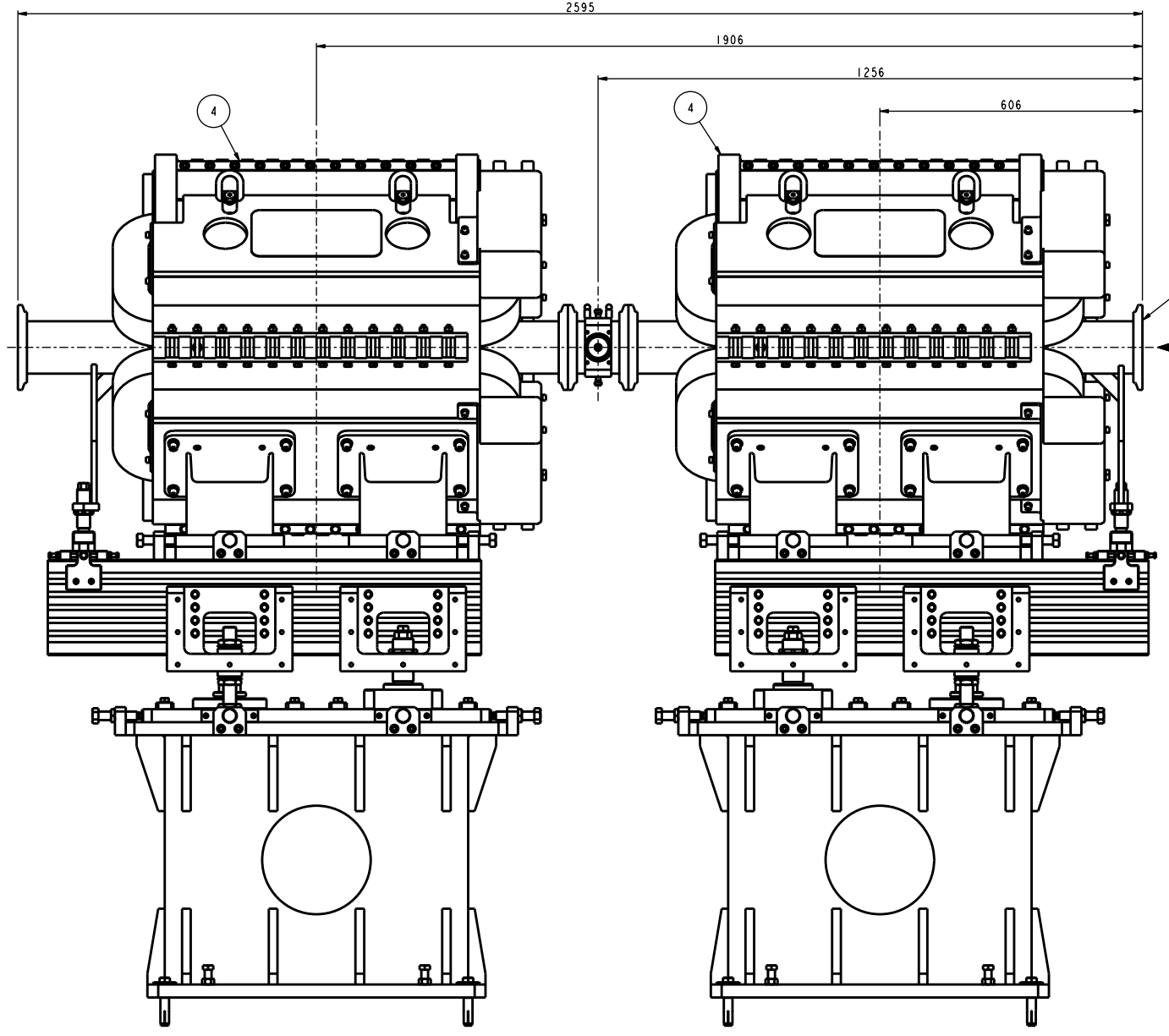
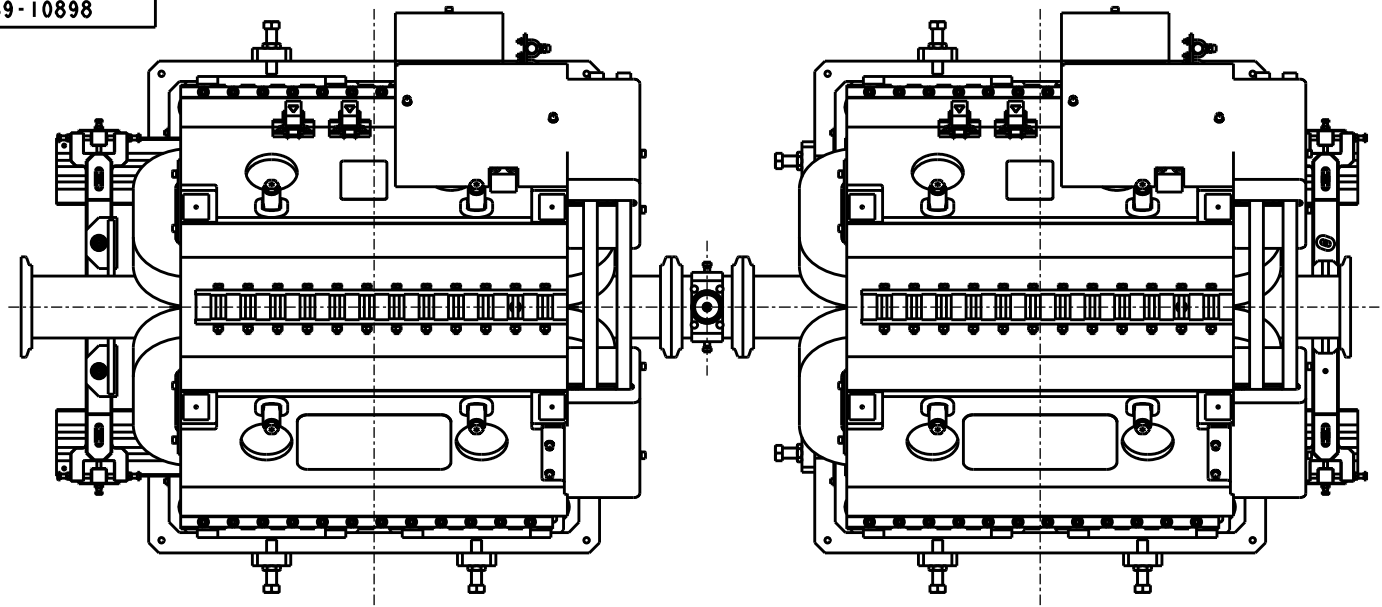

RELEASE STATUS		<b>Approved</b>	
WELDING SPEC.		.....	
MATERIAL SPEC.		.....	
MATERIAL		.....	
TOLERANCES UNLESS OTHERWISE STATED			
LINEAR DIMENSIONS UP TO ± . . . OVER ± . . .			
ANGULAR DIMENSIONS ± . . .			
ALL DIMENSIONS IN mm UNLESS OTHERWISE STATED			
<b>TOLERANCING ISO 8015</b>			
DRN.	KPD	SCIENCE AND TECHNOLOGY FACILITIES COUNCIL	
DATE.	25/11/19	<b>DARESBURY LABORATORY</b>	
CKD.	RJS	CHESHIRE	
DATE.	27/11/19	TITLE	
APPD.	RJS	ESS BEAM TRANSPORT	
DATE.	27/11/19	A2T1 ASSEMBLY	
DRG. NO.		SHEET 1 OF 2	
<b>AO 289-10898</b>		ISSUE	
PIC. CAP. PART No.		<b>A</b>	
USED ON		289-10940	

THIS DRAWING IS THE PROPERTY OF STFC AND MAY NOT BE COPIED OR USED FOR ANY PURPOSE OTHER THAN THAT FOR WHICH IT IS SUPPLIED WITHOUT THE EXPRESS WRITTEN AUTHORITY OF STFC.

THE ENVELOPE REQUIREMENT (E) APPLIES TO ALL FEATURES OF SIZE UNLESS OTHERWISE STATED. SEE ISO 14405-1 FOR DETAILS.

**A** FIRST ISSUE

DRG. NO. SHEET 2 OF 2  
**AO 289-10898**

CONFORMS TO BS 8888 THIRD ANGLE PROJECTION

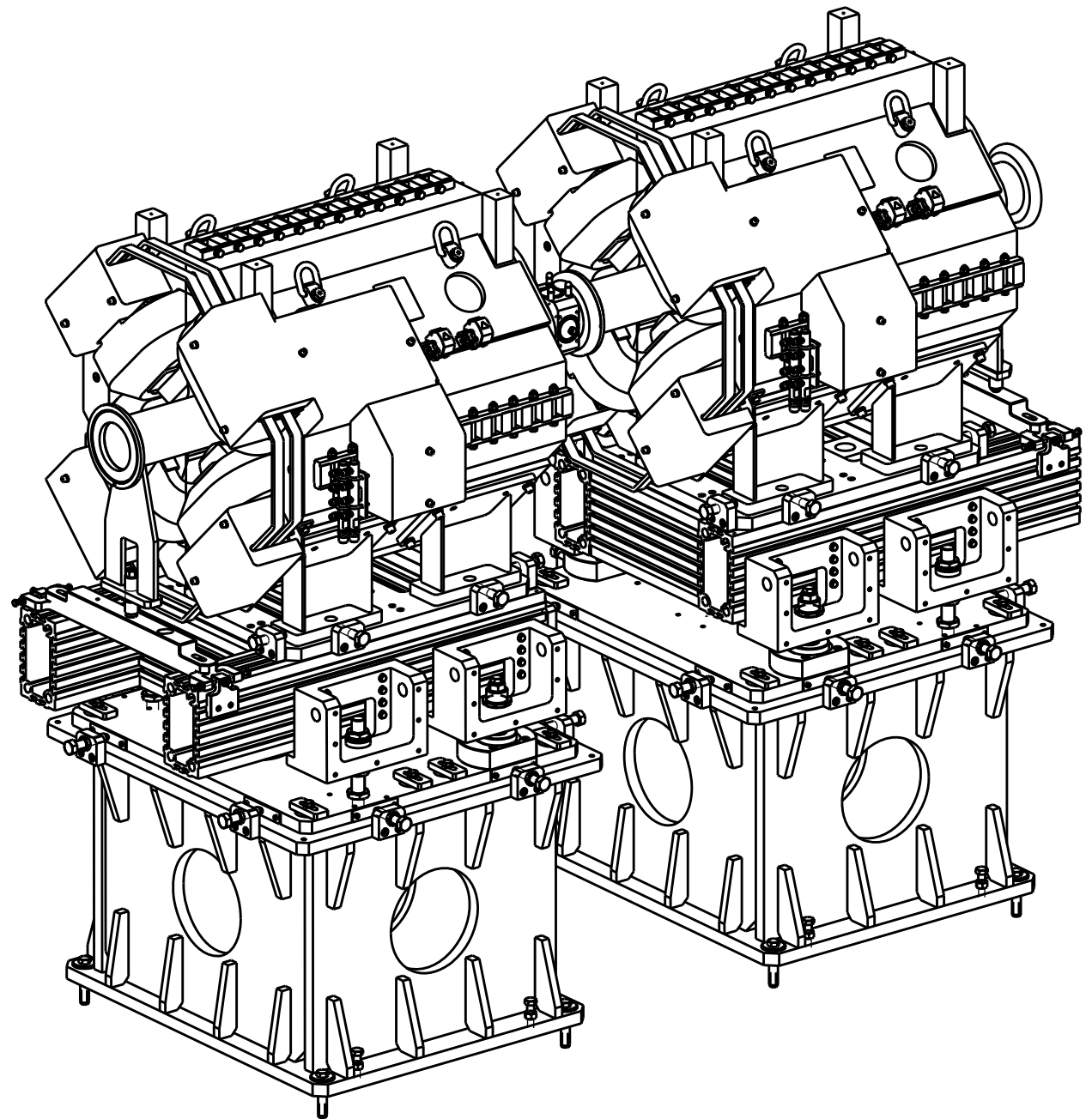
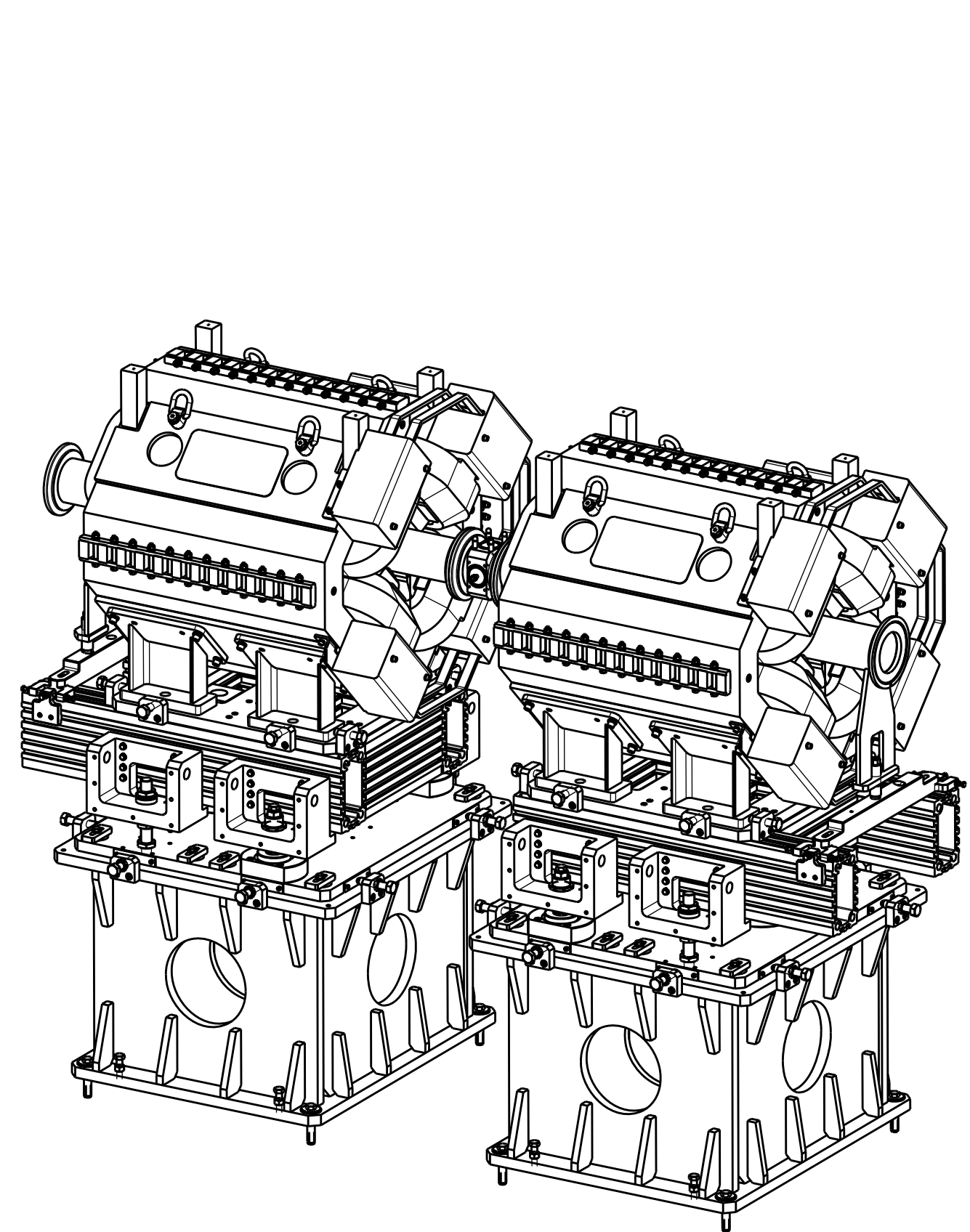

FIRST ISSUE  
 A

THIS DRAWING IS THE PROPERTY OF STFC AND MAY NOT BE COPIED OR USED FOR ANY PURPOSE OTHER THAN THAT FOR WHICH IT IS SUPPLIED WITHOUT THE EXPRESS WRITTEN AUTHORITY OF STFC.  
 THE ENVELOPE REQUIREMENT (E) APPLIES TO ALL FEATURES OF SIZE UNLESS OTHERWISE STATED. SEE ISO 14405-1 FOR DETAILS.

RELEASE STATUS		Approved	
WELDING SPEC.		.....	
MATERIAL SPEC.		.....	
MATERIAL		.....	
TOLERANCES UNLESS OTHERWISE STATED			
LINEAR DIMENSIONS UP TO ..... OVER ± ..			
ANGULAR DIMENSIONS ± ..			
ALL DIMENSIONS IN mm UNLESS OTHERWISE STATED			
<b>TOLERANCING ISO 8015</b>			
DRN.	KPD	SCIENCE AND TECHNOLOGY FACILITIES COUNCIL	
DATE.	25/11/19	<b>DARESBURY LABORATORY</b>	
CKD.	RJS	CHESHIRE	
DATE.	27/11/19	TITLE	
APPD.	RJS	ESS BEAM TRANSPORT	
DATE.	27/11/19	A2T1 ASSEMBLY	
DRG. NO.		SHEET 2 OF 2	
<b>AO 289-10898</b>		ISSUE	
P/C CAD PART No		A	
USED ON		289-10940	