



# BEER

## Instruments status update

PRESENTED BY JOCHEN FENSKE & GREGOR NOWAK & PREMEK BERAN

2024-04-16

# BEER



## Instrument team



**Nuclear Physics Institute CAS**  
Czech Republic

Přemysl Beran  
Jan Šaroun (PL+S)  
Bojan Peric (LE? – 20%)



**Helmholtz-Zentrum Hereon**  
Germany

Gregor Nowak (LS – 90%)  
Jochen Fenske (PL – 70%)  
Dirk Jan Siemers (LE – 70%)  
Sven Kleeband (new engineer)  
Joerg Burmester (MCA& detectors 30%)

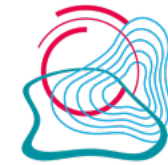

Helmholtz-Zentrum  
**hereon**

## Tranche 2 instrument!

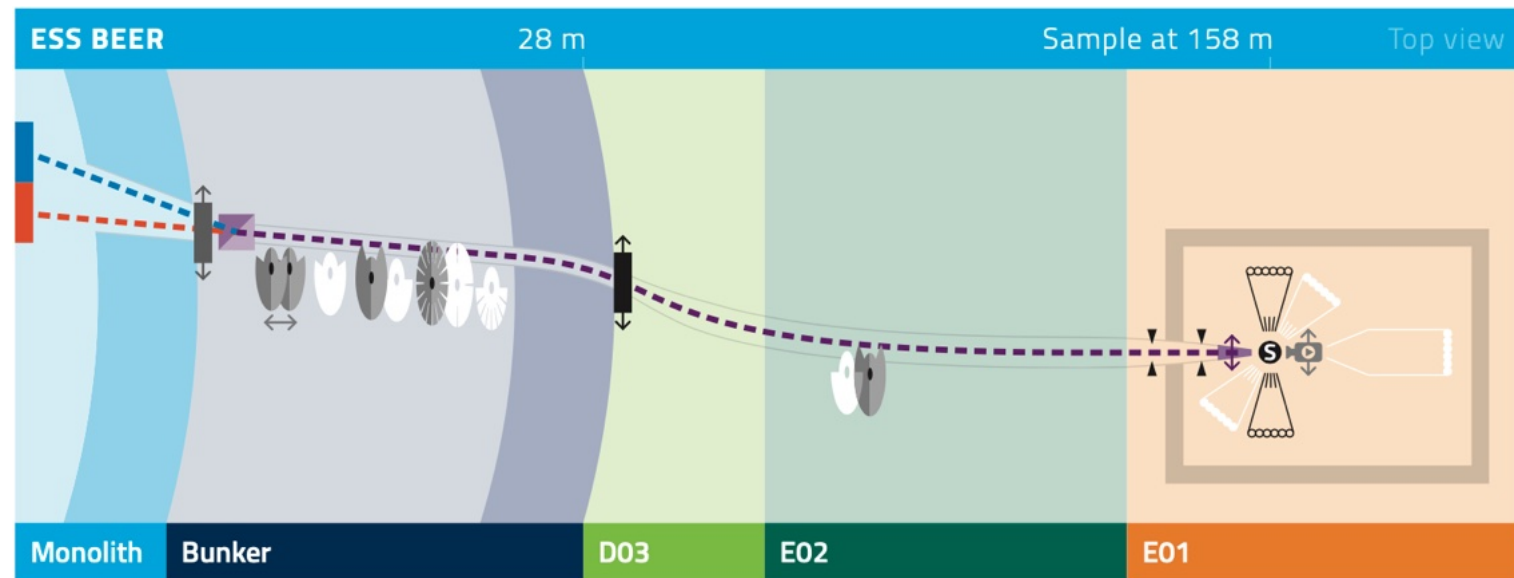

PL – project leader  
LS – lead scientist  
LE – lead engineer  
S - scientist

# BEER

## Components status after re-planning

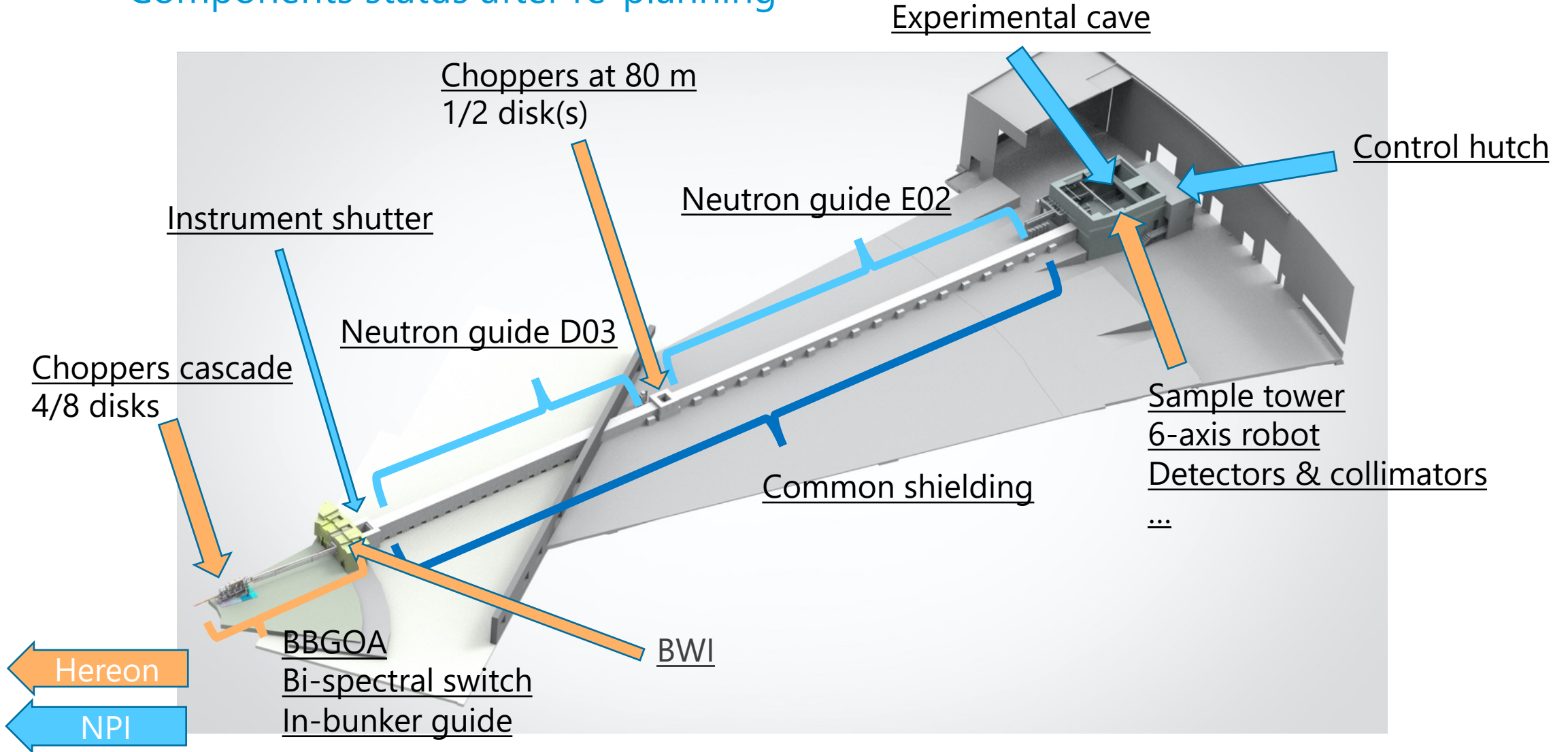

# BEER

## General status update summary



- **Neutron guide** out of the bunker **installed** (113 m)
  - Missing the in-shutter pit part (3 m) and the part going to the cave (12 m)
  - Waiting for BWI and cave installation
- **Common shielding installed** along the out-of-bunker guide
  - Missing the shutter/chopper pit and connection to the cave
- **Shutter** tested and **delivered** to site
  - Waiting for the installation of BWI
- The **cave & hutch** tender to be **signed** this week(-ish)
- Engagement in CUP and CEP
  - Collecting all the necessary requirements
- **Documentation** in **progress** (invisible work behind the scenes)
  - The approval process of the main TG3 documents is in good progress
  - Q-gate documentation for the shutter and the rest of the guide system is under evaluation

# BEER



## General status update summary

- The **6-axis robotic arm** and two sets of **collimators** were **delivered** to the site
- **Hexapod** and **rotary stage** in the **manufacturing** process
- Sample tower and detector support structure design postponed
- **Bi-spectral switch** manufacturing **finished**
  - The test on iMat@ISIS will be in May
- **Chopper cascade**, guide system in bunker and support structure under detailed **design** process
  - Installation in-bunker dependent on the bunker opening before and after BoT
  - Very challenging design with many interfaces (choppers/support/guide/vacuum/remote handling)
- The **detector** issues
  - **Usage** of  $\text{CF}_4$  gas was solved
  - Additional funding has been approved, and **manufacturing** is about to **start soon**
- Software (see Soren's talk)
  - **Very little progress** since the last STAP; only recent work restart
  - Focus on multiplication data reduction process

# BEER

## General status update summary

- The **re-planning** exercise showed a **further delay**
  - TG5 is now in Oct/26
  - Delay mainly resource loaded
  - Detector support and sample tower design on the critical path
- **Lead engineer** temporarily (??) **re-assigned** to ODIN
  - A task-based approach to getting support
  - Possible delay not evaluated yet



# BEER

## NPI update

- Neutron guide out of the bunker (**Installed**)
- Common shielding (**Installed**)



# BEER

## NPI update

- Instrument shutter (tested & delivered)
- Cave & hutch (tender signature this week)
- CDR in Oct/24
  - Start of installation Jan/25
  - End of installation Jun/25

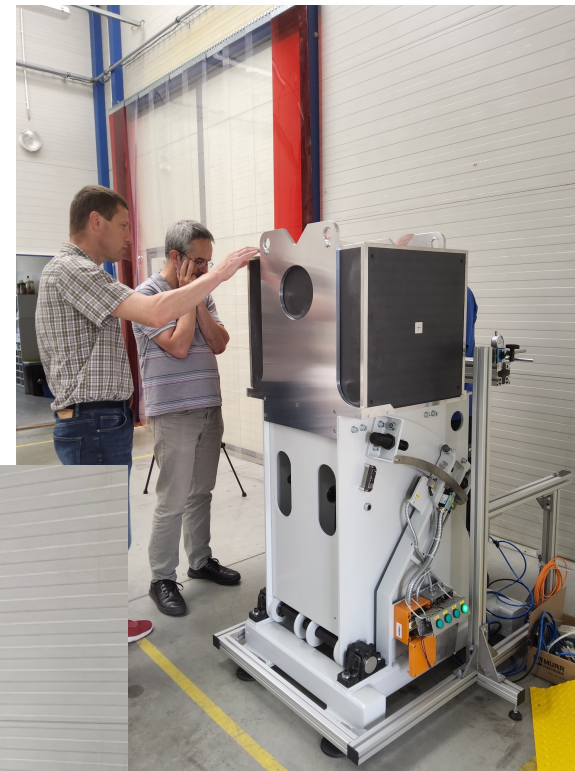
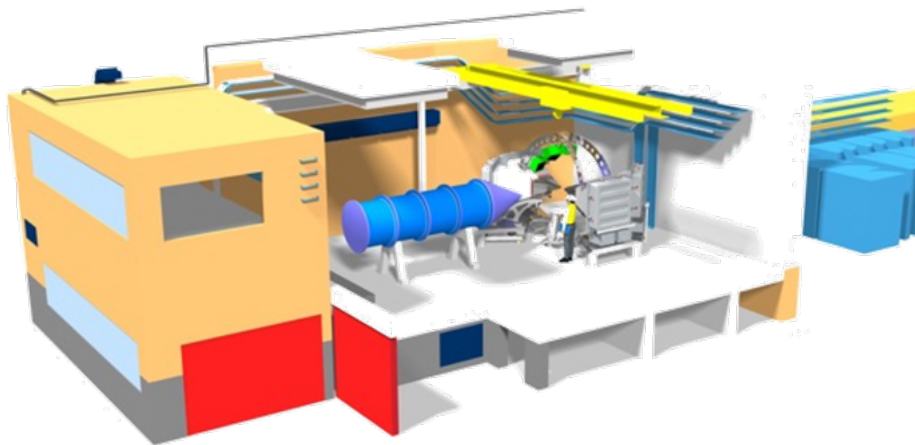



# BEER

## Hereon update



- Neutron Optics in-bunker
  - BBG and BWI are in the manufacturing
  - Lack of neutrons for Quality tests of the coatings
- The chopper and the in-bunker guides
  - The design is close to the finish
- Bi-spectral switch manufactured
  - Test of the optic stack on iMat @ISIS in May
- Choppers
  - CDR 23<sup>rd</sup> of April
  - The support structure is under design,
  - Challenging work on cable routing and remote handling capabilities

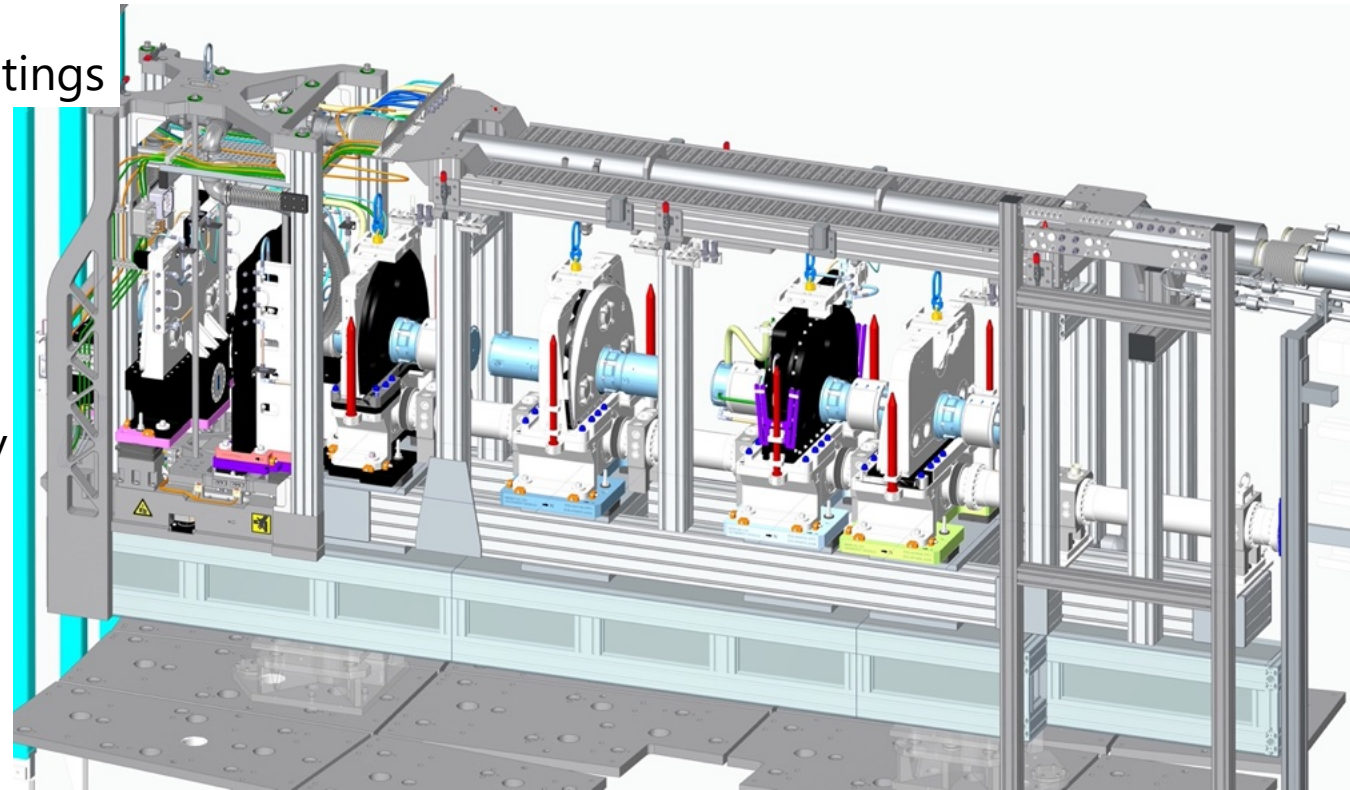

# BEER

## Hereon update

- Radial collimators
  - Optical devices delivered to ESS
  - Manipulator is under manufacturing
- Hexapod & Rotary Stage
  - Manufacturing is ongoing (challenges with Rotary Stage from Huber)
  - FAT expected for mid of May
- 6-axis Robotic Arm
  - Delivered to ESS
  - Integration under discussion with ESS



# BEER

## Hereon update



### ➤ Detector and Beam Monitors

- Discussion with the ESS safety committee regarding the use of  $\text{CF}_4$  gas
- Design Update of gas handling system
- Converter blades already approved for manufacturing

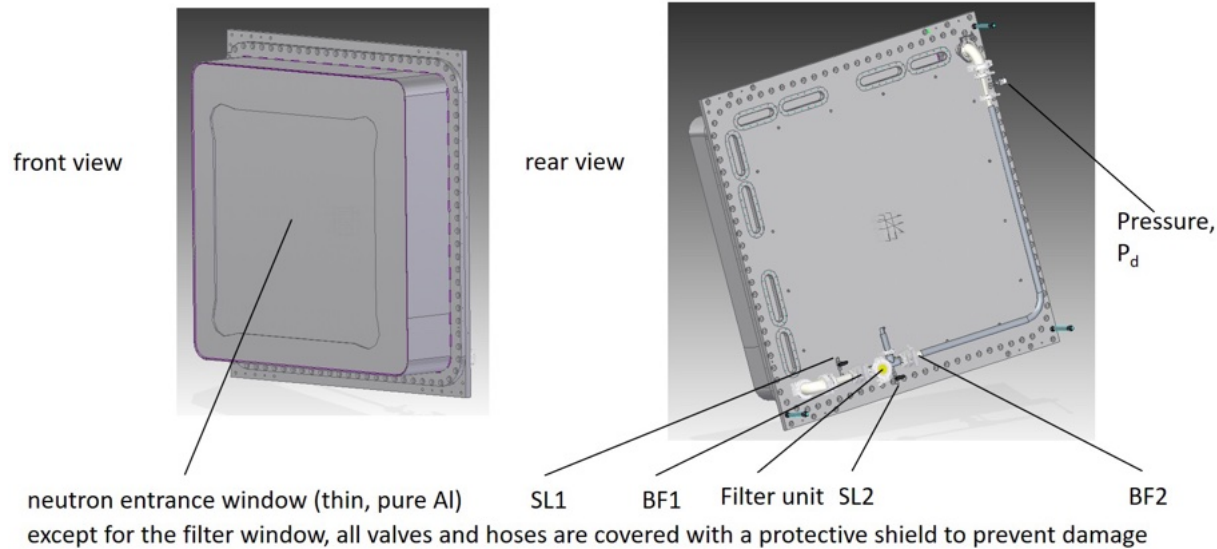

### Evacuation state

#### PID

pump 1 until  $P_d < 50\text{mbar}$  than pump2

no emission

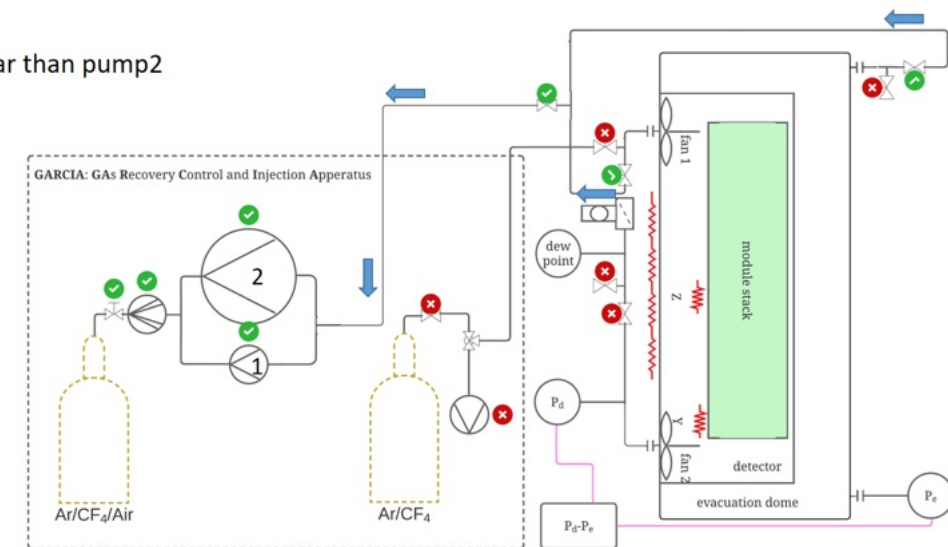

# BEER

## Components status after re-planning

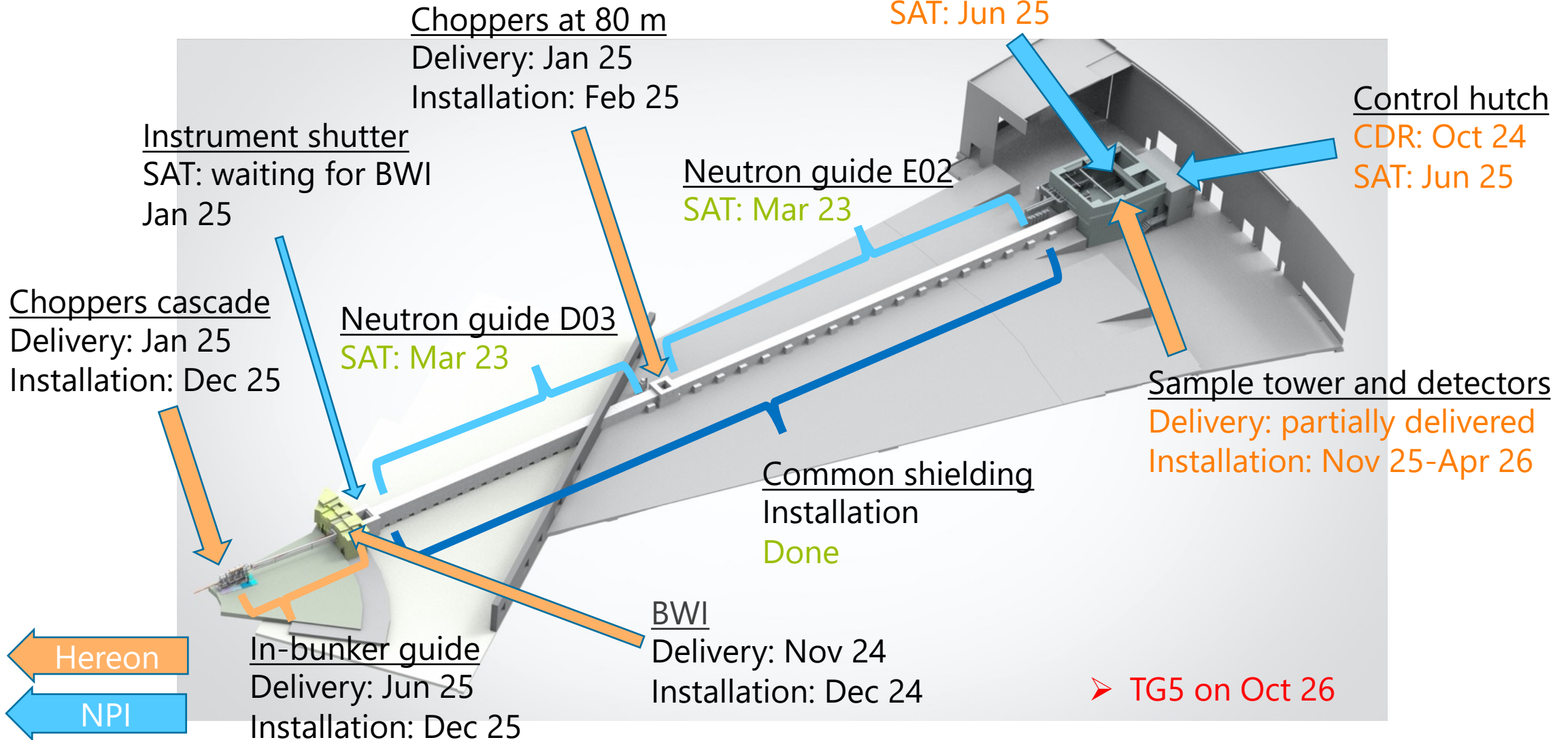



# BEER

## What we struggle with

- Communication with in-kind partners, technical groups, ...
- Rules and new requirements are placed with time – it is difficult to catch up
- Long review process – one needs to chase the feedback
- Q-gate – new showstopper
- Lack of understanding of how the instrument team should look like
  
- Multiple roles of LS – project manager, planner, engineer survey, technical writer, ..., ..., ..., scientist, ... but the last in the chain
- *I have a feeling* that scientists' voice at ESS is not recognised